

TIMER 300

Continuous-Running Version

Warranty and Service

Your *Novel Electronic Designs* Timer 300 has a one year warranty (parts and labor). All warranty service must be performed by NED.

NED's repair service is quick and economical.

The latest copy of this manual is available at this link:

<http://www.BuzzerSystems.com/doc>

Contacting Us

Our up-to-date contact information is at our website

<http://www.BuzzerSystems.com>

Connecting Timer to your Buzzer System

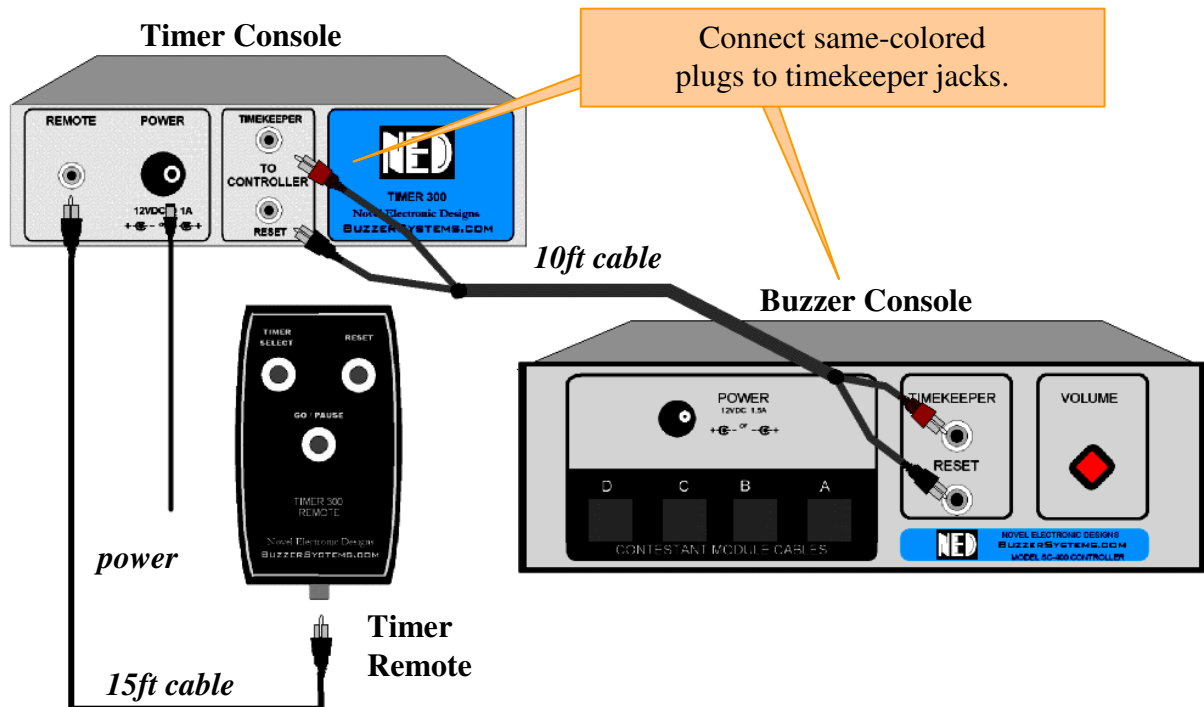

Novel Electronic Designs, Inc.
BUZZERSYSTEMS.COM

Timer Controls

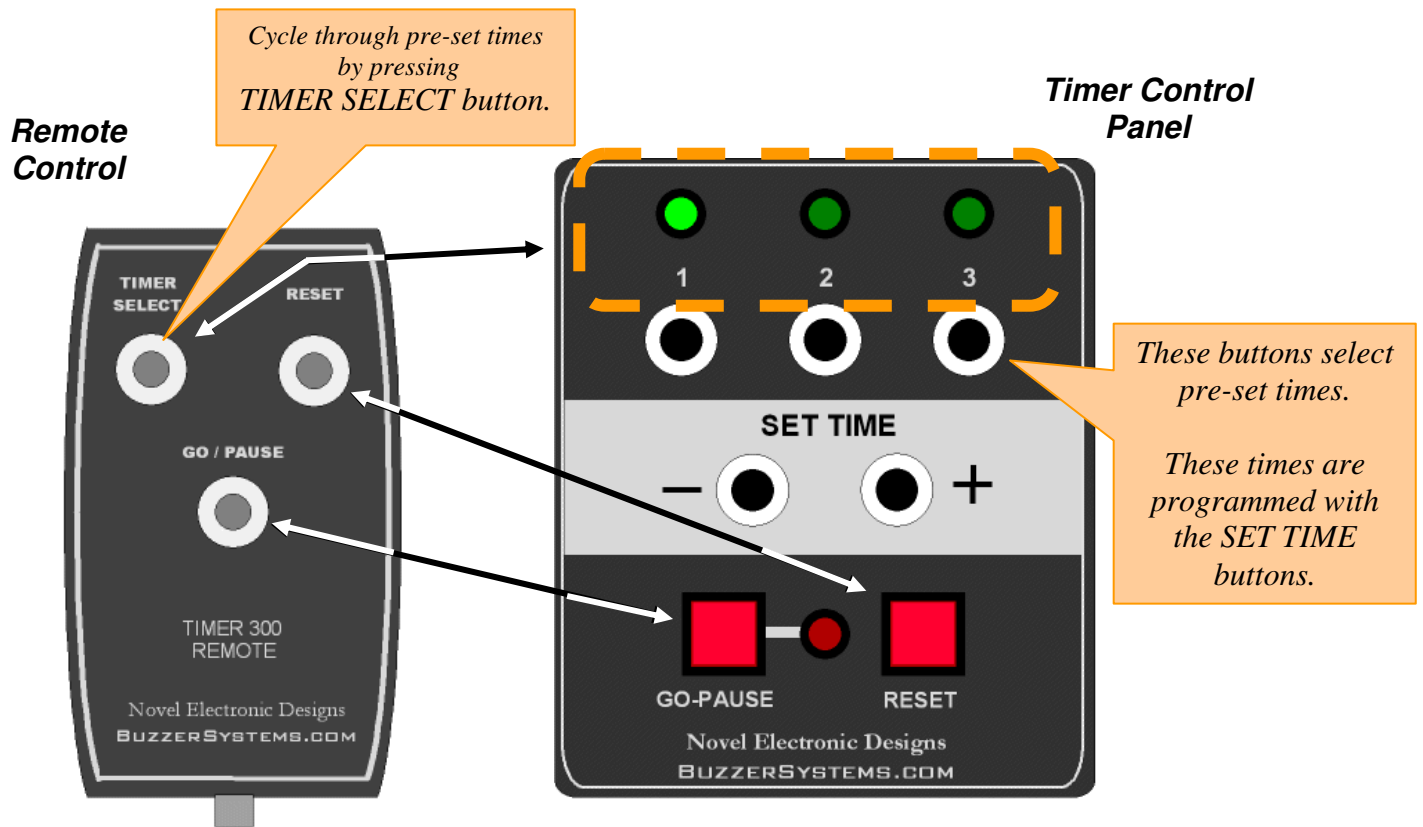

Press the **go-pause** button when it's time for a player to respond to a question; refresh the timer with the **reset** button.

See flowchart "Using the Timer 300" for details.

The timer has three convenient pre-set times. Program each pre-set time with the **set time** buttons on the control panel.

Pre-set times range from 3 seconds to 9 minutes 59 seconds.

Novel Electronic Designs, Inc.
BUZZERSYSTEMS.COM

Using the Timer 300



Timer's hand-held remote controls timer and buzzer system during questions.

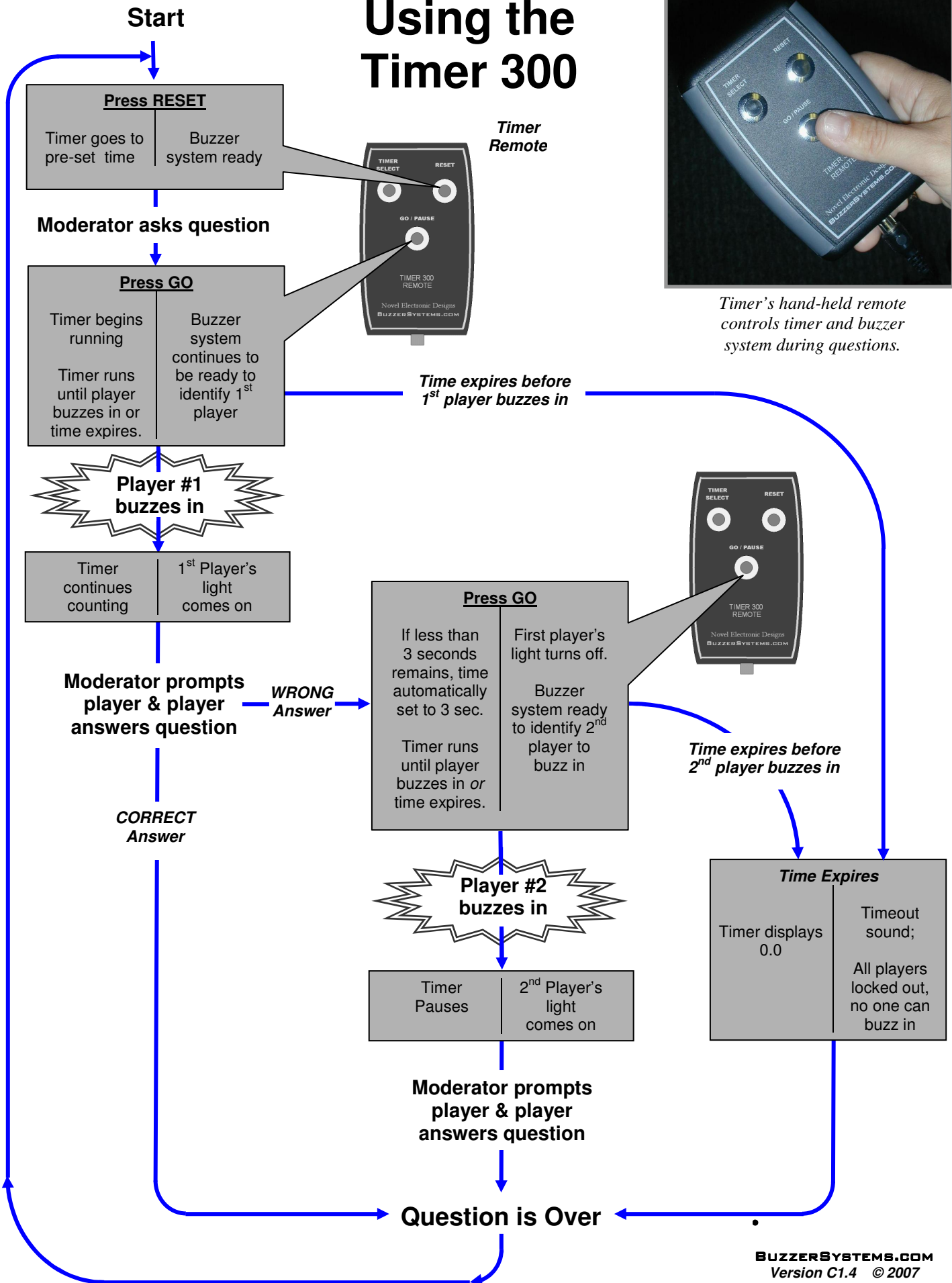

<i>Troubleshooting</i>		
<i>Symptom</i>	<i>Cause</i>	<i>What to do...</i>
Timer doesn't light up	Power pack defective	Try powering the timer with your buzzer system power pack – replace power pack
Timer doesn't set to desired time	Timer has fixed starting times	If you need a specific time not presently available, please contact BuzzerSystems.com
Buzzer Console doesn't trigger timer when someone buzzes in	Buzzer console not compatible with timer	Check bottom of controller for a sticker indicating its compatible with TIMER 300. Contact BuzzerSystems.com to have buzzer console updated.
	Controller malfunction	See buzzer console manual for troubleshooting suggestions
	No cable between timer and controller	Install cable
	Timer/controller cable not plugged in completely and/or connections are swapped	Check cable and make necessary changes
Buzzer Console doesn't "timeout" when time expires	No cable between timer and controller	Install cable
	Timer/controller cable not plugged in completely and/or connections are swapped	Check cable and make necessary changes
Digits are dim	Power Pack Faulty	Replace power pack
	Incorrect Power Pack being used	Use correct power pack, or contact BuzzerSystems.com for replacement.
Timer resets while counting	Intermittent AC Power	Replace power pack
	Power pack's cable or connector damaged	
	Power pack plugged into worn or loose outlet	Change to a different outlet
Remote control intermittent or not functional	Faulty cable	Replace cable
	Remote Control cable not connected correctly	Ensure remote control cable is plugged into REMOTE connector on timer Make sure connectors at both timer and remote are fully inserted.
Buzzer Console signals "timeout" when timer is reset	Cable connectors between buzzer and timer are swapped	Make sure cables are installed correctly (timekeeper to timekeeper, reset to reset)

Novel Electronic Designs, Inc.
BUZZERSYSTEMS.COM